

Isolated intrinsically safe two wire transmitter
DAT 4035 IS
DAT 4035 IS / HT



FEATURES

- **PROTECTION MODE: II 1 G Ex ia IIC**
 certified in according with the Directive ATEX 94/9/EC
- **Applicable in zones with explosion risk (ZONE 0)**
- **Configurable input for RTD, mV, Tc, Resistance and Potentiometer**
- **4 ÷ 20 mA configurable output on current loop**
- **Galvanic isolation at 2000 Vac**
- **Configurable by Personal Computer, on-field reconfigurable**
- **High accuracy**
- **EMC compliant – CE mark**
- **Suitable for DIN rail mounting in compliance with EN-50022 and EN50035**

GENERAL DESCRIPTION

The isolated transmitter DAT 4035 IS is able to execute many functions such as : measure and linearisation of the temperature characteristic of RTDs sensors, conversion of a linear resistance variation, conversion of a voltage signal even coming from a potentiometer connected on its input. Moreover the DAT 4035 IS is able to measure and linearise the standard thermocouples with internal cold junction compensation. The measured values are converted in a 4÷20 mA current signal . The device guarantees high accuracy and performances stability both in time and in temperature. The programming of the DAT 4035 IS is made by a Personal Computer using the software PROSOFT, developed by DATEXEL, that runs under the operative system "Windows™ ". By use of PROSOFT, it is possible to configure the transmitter to interface it with the most used sensors . In case of sensors with a no-standard output characteristic, it is possible to execute, via software, a "Custom" linearisation (per step) to obtain an output linearised signal. For Resistance and RTDs sensors it is possible to program the cable compensation with 3 or 4 wires; for Thermocouples it is possible to program the Cold Junction Compensation (CJC) as internal or external. It is possible to set the minimum and maximum values of input and output ranges in any point of the scale, keeping the minimum span shown in the table below. Moreover it is available the option of alarm for signal interruption (burn-out) that allows to set the output value as high or low out of scale . The 2000 Vac isolation between input and power supply/output eliminates the effects of all ground loops eventually existing and allows the use of the transmitter in heavy environmental conditions found in industrial applications. The DAT 4035 IS is in compliance with the standard 89/336/CEE on the Electromagnetic Compatibility. It is housed in a plastic enclosure of 12.5 mm thickness suitable for DIN rail mounting in compliance with EN-50022 and EN-50035 standards.

USER INSTRUCTIONS.

The 4÷20 mA output signal is measurable in the power loop as shown in the section "Output/Power supply connections"; Rload is the input impedance of instruments on the current loop; to obtain a correct measure, the value of Rload will be calculated as function of the power supply value (see section "Technical specification – Load characteristic"). The input connections must be made as shown in the section "Input connections". To configure, calibrate and install the transmitter refer to sections " DAT 4035 IS: configuration and calibration" and "Installation Instructions".

- In order to guarantee a correct and safe operation of the transmitter the following requirements must be strictly satisfied
- 1) **The power supply voltage (intrinsically safe) applied between the terminals M and N must be included between 11 V and 30 Vdc values.**
 - 2) **The maximum power supplied by the safety barrier must be not higher than 0.75 W.**

Ex data

Output / supply	Input
U _i = 30 V I _i = 100 mA P _i = 0.75 W L _i = 0.1 mH C _i = 10 nF	U _o = 6.2 V I _o = 100 mA P _o = 500 mW L _o = 3.6 mH C _o = 5 uF
T ₆ : -20 ÷ +55°C T ₅ : -20 ÷ +70°C T ₄ : -20 ÷ +85°C ('HT' vers.)	

TECHNICAL SPECIFICATIONS (Typical at 25 °C and in nominal conditions)

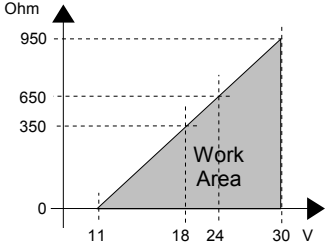
Input type	Min	Max	Min. span	Input calibration (1)	Response time (10÷90%)
TC(*) CJC int./ext.				RTD > of ±0.1% f.s. or ±0.2°C Low res. > of ±0.1% f.s. or ±0.15 Ω High res. > of ±0.2% f.s. or ±1 Ω mV, Tc > of ±0.1% f.s. or ±18 uV	about 400 ms
J	-200°C	1200°C	2 mV	Output calibration Current ± 7 uA	Power supply Power supply voltage 11 .. 30 Vdc Reverse polarity protection 60 Vdc max
K	-200°C	1370°C	2 mV	Input impedance mV, Tc ≥= 10 MΩ	Isolation voltage Input – Power supply 2000 Vac, 50 Hz, 1 min.
S	-50°C	1760°C	2 mV	Linearity (1) Tc ± 0.2 % f.s. RTD ± 0.1 % f.s.	Load characteristic - Rload (maximum load value on current loop per power supply value)
R	-50°C	1760°C	2 mV	Line resistance influence mV, Tc ≤=0,8 uV/Ohm	
B	400°C	1820°C	2 mV	RTD 3 wires 0.05%/Ω (50 Ω balanced max.) RTD 4 wires 0.005%/Ω (100 Ω balanced max.)	Temperature & humidity Operative temperature -20°C .. +70°C 'HT' vers: -20°C .. +85°C
E	-200°C	1000°C	2 mV	RTD excitation current Typical 0.350 mA	Storage temperature -40°C .. +85°C Humidity (not condensed) 0 .. 90 %
T	-200°C	400°C	2 mV	CJC comp. ± 0.5°C	Housing Material Self-extinguish plastic Mounting DIN rail in compliance with EN-50022 and EN-50035
N	-200°C	1300°C	2 mV	Thermal drift (1) Full scale ± 0.01% / °C CJC ± 0.01% / °C	Weight about 90 g.
RTD(*) 2,3,4 wires				Burn-out values Max. value about 22.5 mA Min. value about 3.6 mA	EMC (for industrial environments) Immunity EN 61000-6-2 Emission EN 61000-6-4
Pt100	-200°C	850°C	50°C	(1) referred to input Span (difference between max. and min. values)	
Pt1000	-200°C	200°C	50°C		
Ni100	-60°C	180°C	50°C		
Ni1000	-60°C	150°C	50°C		
Voltage					
mV	-100mV	+700mV	2 mV		
Potentiometer (Nominal value)					
	0 Ω	200 Ω	10%		
	200 Ω	500 Ω	10%		
	0.5 KΩ	2 KΩ	10%		
RES. 2,3,4 wires					
Low	0 Ω	300 Ω	10 Ω		
High	0 Ω	2000 Ω	200 Ω		
Output type	Min	Max	Min. span		
Direct current	4 mA	20 mA	4 mA		
Reverse current	20 mA	4 mA	4 mA		

(*) For temperature sensors it is possible to set the input range also in F degrees; to made the conversion use the formula: °F = (°C*9/5)+32)

DAT 4035 IS: CONFIGURATION AND CALIBRATION

Warning: during these operations the device must always be powered by a safety barrier; to connect the interface Prodat, use the protection cable CVPR-03.

- CONFIGURATION

- 1) Power-on the DAT 4035 IS by a safety barrier (see Ex data) .
- 2) Remove the protection plastic cap on DAT 4035 IS.
- 3) Connect the interface PRODAT to the Personal Computer and to device. using the protection cable CVPR-03. (see section "DAT 4035 IS: PROGRAMMING") .
- 4) Run the software PROSOFT.
- 5) Set the parameters of configuration .
- 6) Program the device.

- CALIBRATION CONTROL

With software PROSOFT running:

- 1) Connect on the input a calibrator setted with minimum and maximum values referred to the electric signal or to the temperature sensor to measure.
- 2) Set the calibrator at the minimum value.
- 3) Verify that the DAT 4035 IS provides on output the minimum setted value.
- 4) Set the calibrator at the maximum value.
- 5) Verify that the DAT 4035 IS provides on output the maximum setted value.
- 6) In case of regulation of value obtained in the step 3 and 5, use the ZERO and SPAN regulators of software PROSOFT. The variation introduced from these regulators must be calculated as percentage of the input range .
- 7) Program the device with the new parameters .

DAT 4035 IS: PROGRAMMING

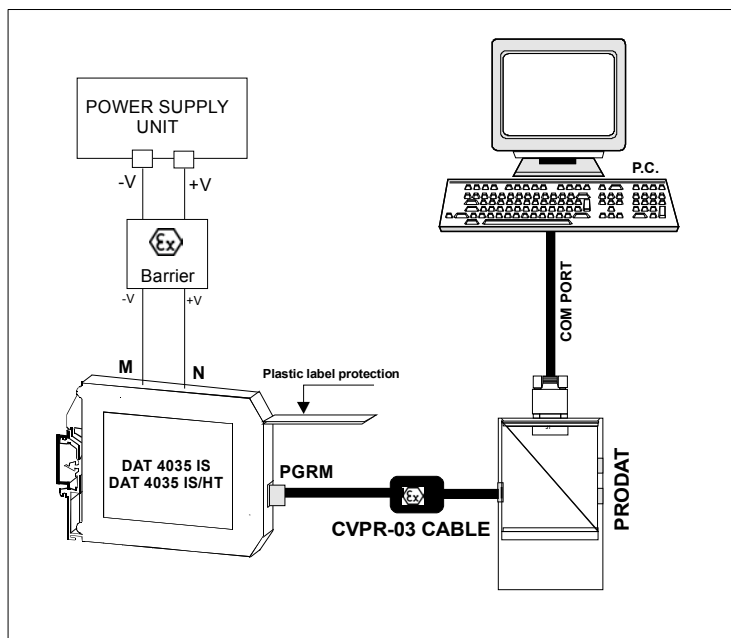

DIMENSIONS (mm) & CONNECTOR PGRM

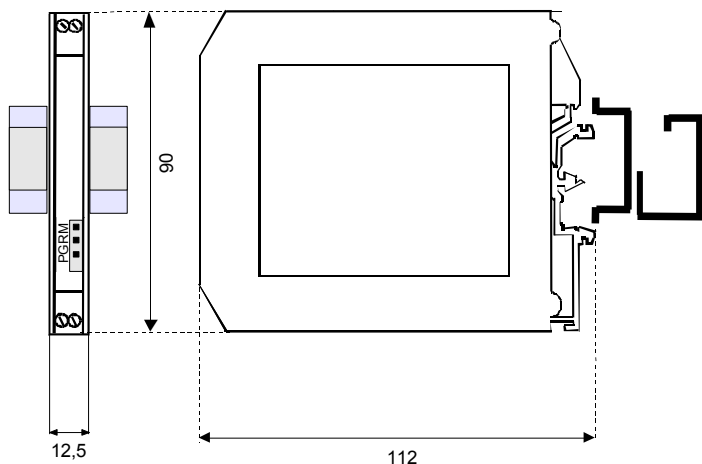

INSTALLATION INSTRUCTIONS

In order to guarantee the safety requirements, before to install the device, refer to the "Safety Instructions" provided with the device.

The transmitter must be mounted in order to guarantee to it an IP54 protection grade or more for external environments and an IP4X protection grade or more for internal environments or protected area. The device DAT 4035 IS is suitable for DIN rail mounting. It is necessary to install the device in a place without vibrations; avoid to routing conductors near power signal cables .

DAT 4035 IS: CONNECTIONS

INPUT CONNECTIONS

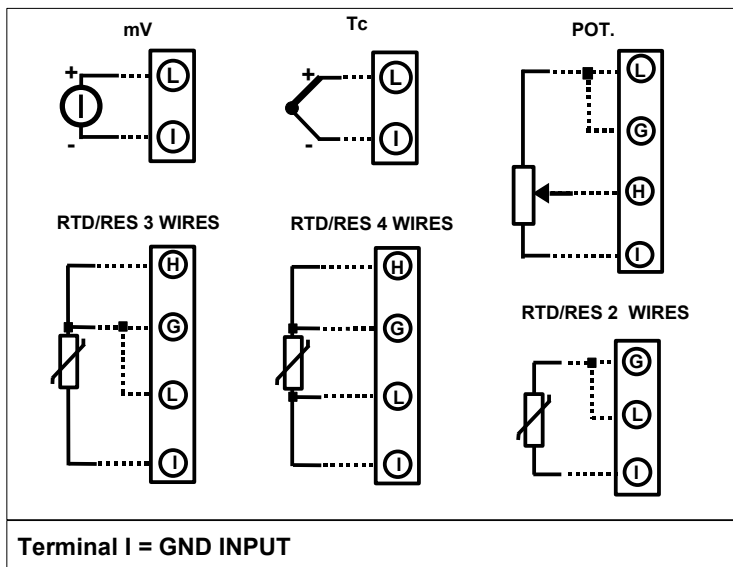

OUTPUT/POWER SUPPLY CONNECTIONS

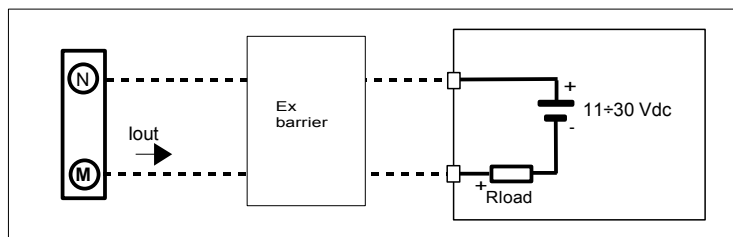

ISOLATION STRUCTURE

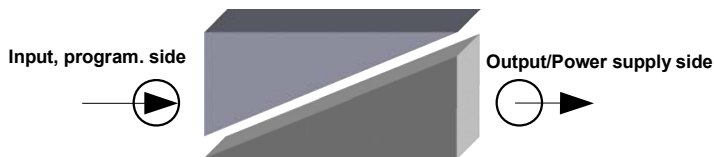

HOW TO ORDER
 The DAT 4035 IS is provided as requested on the Customer's order. Refer to the section "Technical specification" to determine input and output ranges. In case of the configuration is not specified, the parameters must be set by the user.

ORDER CODE:
DAT 4035 IS / Pt100 / 3 wires / 0 ÷ 200 °C / S.L. / 4 ÷ 20 mA / Burn-out up
DAT 4035 IS/HT

Input type: Pt100
 Sensor options: RTD/RES:2,3,4 wires
 Tc: CJC int. or ext.
 Input range: 0 ÷ 200 °C
 Output range: 4 ÷ 20 mA
 Burn-out up: High or low Out of scale

(*) Linearisation options:
 S.L.: standard linearisation.
 N.L.: no linearisation.
 C.L.: linearisation by step (Custom): specify input curve