

DAT 4530

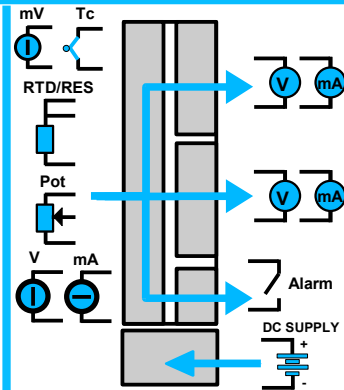

FEATURES

- Universal configurable input for: mV, Tc, RTD, Res, Potentiometer, V and mA
- Two outputs configurable in current or voltage
- Trip alarm
- Configurable by dip-switch or PC
- High accuracy
- On-field reconfigurable
- Galvanic isolation among all the ways
- EMC compliant – CE mark
- Suitable for DIN rail mounting in compliance with EN-50022 and EN-50035



GENERAL DESCRIPTION

The universal isolated converter DAT 4530 is able to measure and linearise voltage, current and resistance signals, potentiometers and the standard thermocouples and RTDs with, if required, the cold junction compensation, the wires compensation. For mV, V and mA input it is possible to set an option for the fast sampling (option HS) or to extract the square root of the measured signal (option SQRT). In function of programming, the measured values are converted in a current or voltage signal on the two outputs. Moreover an output contact is available as trip alarm.

The device guarantees high accuracy and performances stability both versus time and temperature.

The programming is made by the dip-switch located in the window on the side of the enclosure. By means of dip-switches it is possible to select the input type and range and the output type without recalibrate the device.

Moreover, by Personal Computer the user can program all of the device's parameters for his own necessity and the trip alarm 's settings.

The 1500 Vac galvanic isolation on all ways (input, outputs and power supply) eliminates the effects of all ground loops eventually existing and allows the use of the converter in heavy environmental conditions found in industrial applications.

The DAT 4530 is in compliance with the standard 89/336/EEC on the Electromagnetic Compatibility.

It is housed in a plastic enclosure of 12.5 mm thickness suitable for DIN rail mounting in compliance with EN-50022 and EN-50035 standards.

USER INSTRUCTIONS

The converter must be powered by a direct voltage applied to the terminals U and V.

The analogue channel measures the value from the sensor connected to the terminals C-D-E-F-G-H-I-L and transmits the output measures on the terminals M-N-O-P (OUT A) and the terminals Q-R-S-T (OUT B). A contact for the trip alarm is available on the terminals A-B.

The input and output connections must be made as shown in the section "Connections".

It is possible to configure the converter on field by dip-switch or Personal Computer as shown in the section " Programming ". The configuration by dip-switches can be made also if the device is powered (note: after the configuration the device takes some seconds to provide the right output measure).

TECHNICAL SPECIFICATIONS

(Typical @ 25 °C and in nominal conditions)

INPUT				Linearity (1)				ALARM TRIP					
Input type	Min	Max	Span min	Tc	± 0.2 % f.s.	RTD	± 0.1 % f.s.	Contact	SPST (1Form A)				
TC (CJC int./ext.)				mV, V, mA				Max Load (resistive) :					
J	-200°C	1200°C	100°C	± 0.05 % f.s.				Voltage	48 V (ac/dc)				
K	-200°C	1300°C	100°C	Input impedance				Current	0.4 A				
S	0°C	1750°C	400°C	TC, mV				POWER SUPPLY					
R	0°C	1750°C	400°C	>= 10 MΩ				Power supply voltage		20 .. 30 Vdc			
B	0°C	1850°C	400°C	RTD excitation current				Reverse polarity protection		60 Vdc max			
E	-200°C	1000°C	100°C	RTD, Res				Current consumption					
T	-200°C	400°C	100°C	400 uA				Current output		90 mA max.			
N	-200°C	1300°C	100°C	Aux. Voltage				Voltage output		50 mA max.			
Voltage				>18V @ 20mA				ISOLATION					
mV	-100 mV	+90 mV	5 mV	Line resistance influence (1)				Among all the ways			1500 Vac, 50 Hz, 1 min		
mV	-100 mV	+200 mV	10 mV	TC, mV				TEMPERATURE AND HUMIDITY					
mV	-100 mV	+800 mV	20 mV	RTD 3 wires				Operative temperature			-20°C .. +60°C		
RTD (2, 3, 4 wires)				0.05%/Ω (50 Ω max balanced)				Storage temperature			-40°C.. +85°C		
Pt100	-200°C	850°C	50°C	Thermal drift (1)				Humidity (not condensed)			0 .. 90 %		
Pt1000	-85°C	185°C	30°C	Full scale				HOUSING					
Ni100	-60°C	180°C	50°C	± 0.01% / °C				Material			Self-extinguishing plastic		
Ni1000	-60°C	150°C	30°C	CJC				Mounting			DIN rail in compliance with EN-50022 and EN-50035		
RES. (2, 3, 4 wires)				CJC Comp.				Weight			about 100 g.		
0 Ω	500 Ω	50 Ω	OUTPUT (2 CHANNELS)										
0 Ω	2000 Ω	50 Ω	Output type				Min	Max	Min Span	EMC (for industrial environments)			
Pot. (Rnom.< 50KΩ)				Current				0 mA	20 mA	4 mA	Immunity		EN 61000-6-2
0 %	100 %	10 %	Voltage				0 V	10 V	1 V	Emission		EN 61000-6-4	
Voltage				Output calibration									
0 V	10 V	1 V	Current				± 7 uA						
Current				Voltage				± 5 mV					
0 mA	20 mA	1 mA	Aux. Voltage				>12V @ 20mA						
Calibration (1)				Burn-out values									
mV, TC				Max. output value				22 mA or 11 V					
RTD				Min. output value				0 mA or -0.6 V					
Res.				Output load Resistance - Rload									
Potentiometer				Current output				< 500 Ω					
Voltage				Voltage output				> 10 KΩ					
mA				Short circuit current				30 mA max.					
mV, V, mA				Response time (10÷ 90%)				about 500 ms					
								100 ms (option HS)					

(1) referred to the input Span (difference between max. and min.)

THRESHOLD OPERATION

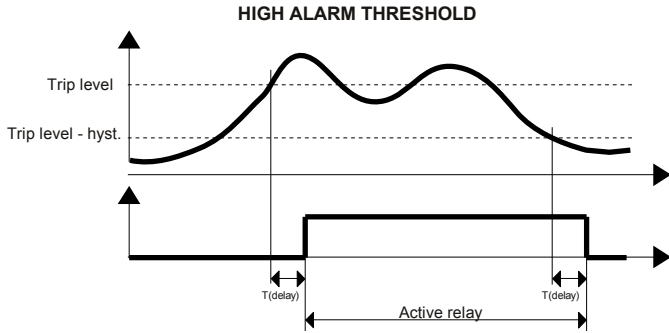

For the high alarm the relay goes on when the input signal is higher than the trip level and after the delay time. The relay goes off only when the input signal is lower than the trip level minus the hysteresis value or when reaches the minimum value of the input scale and after the delay time.

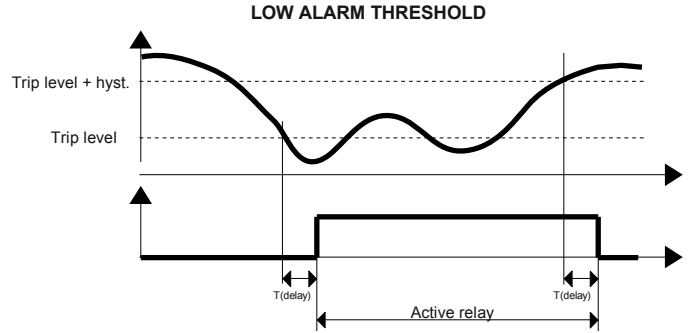

For the low alarm the relay goes on when the input signal is lower than the trip level and after the delay time. The relay goes off only when the input signal is higher than the trip level plus the hysteresis value or when reaches the maximum value of the input scale and after the delay time.

PROGRAMMING

CONFIGURATION BY PC

By software DATESOFT it is possible to:

- set the default programming of the device;
- program the options not available with the dip-switch;
(burn-out level, CJC offset, trip alarm settings, fast sampling, etc...);
- read, in real time, the input and output measures;
- follow the dip-switches configuration wizard.

To configure the device follow the next steps:

- 1) Power-on the device.
- 2) Open the protection plastic label on the front of the device.
- 3) Connect the interface PRODAT to the PC (COM port) and to the device (PGRM connector).
- 4) Open DATESOFT.
- 5) Select the COM port in use.
- 6) Click on "Open COM".
- 7) Click on the icon "Program".
- 8) Set the programming data.
- 9) Click on the icon "Write" to send the programming data to the device.

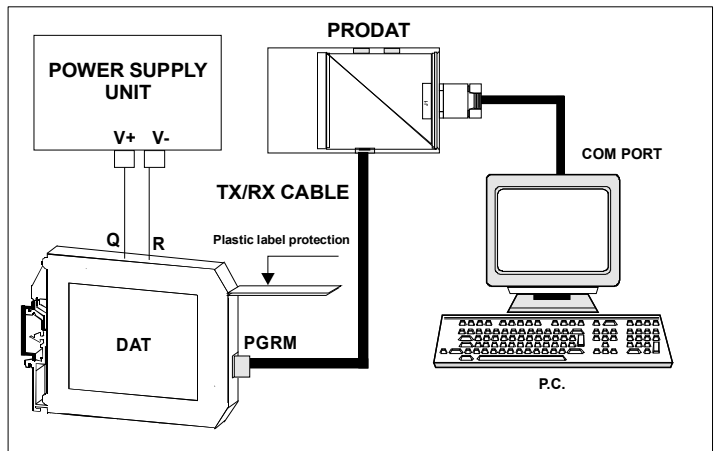

Warning: during these operations the device must always be powered and the TX/RX cable always connected.
For information about DATESOFT refer to the software's user guide.

CONFIGURATION BY DIP-SWITCHES

- 1) Open the suitable door on the side of the device.
- 2) Set the input type by the dip-switch SW1 [1..5] (see TAB.1)
- 3) Set the output A type by the dip-switch SW1 [7..8] (see TAB.2)
- 4) Set the output B type by the dip-switch SW2 [1..2] (see TAB.2)
- 5) Set, if available, the input option by the dip-switch SW1 [6] (see TAB.3)
- 6) Set the maximum input value (Full scale) by the dip-switch SW2 [3..8] (see TAB.4)
- 7) Set the minimum input scale value (Zero) by the dip-switch SW3 [1..4] (see TAB.4)

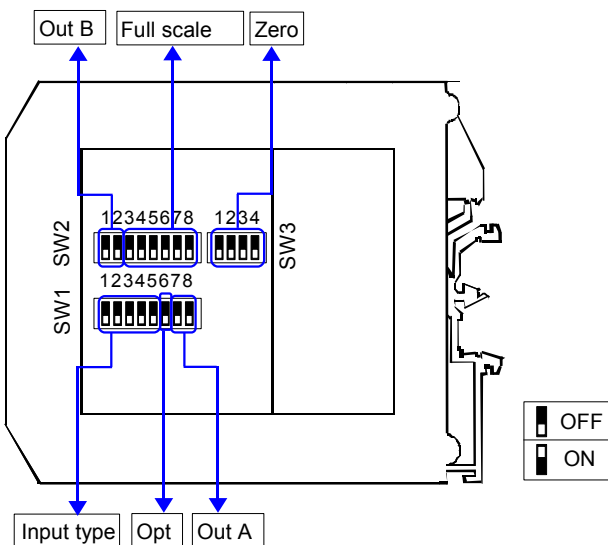

NOTE:

- It is also possible to set the dip-switches using the wizard of the configuration software following the procedure described in the section "Configuration by PC" until the step 6 and clicking on icon "Switch".

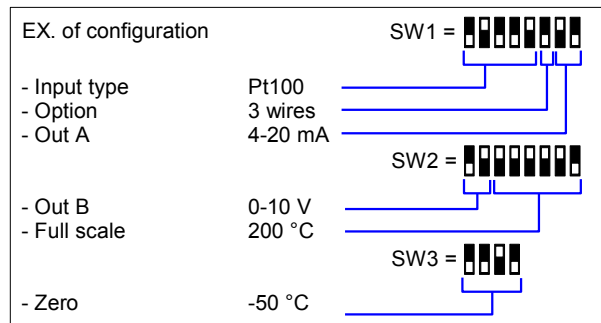

TAB.4c – Resistance < 2 Kohm input scale settings.

Zero				Full Scale																	
SW3				SW2				SW2				SW2									
1	2	3	4	3	4	5	6	7	8	3	4	5	6	7	8	3	4	5	6	7	8
Default				Default				800				1150				1600					
0				500				820				1175				1650					
150				520				840				1200				1700					
200				540				860				1225				1750					
250				560				880				1250				1800					
300				580				900				1275				1850					
350				600				920				1300				1900					
400				620				940				1325				1950					
450				640				960				1350				2000					
500				660				980				1375				2000					
550				680				1000				1400				2000					
600				700				1025				1425				2000					
650				720				1050				1450				2000					
700				740				1075				1475				2000					
750				760				1100				1500				2000					
800				780				1125				1550				2000					

TAB.4d – Resistance < 500 ohm input scale settings

Zero				Full Scale																	
SW3				SW2				SW2				SW2									
1	2	3	4	3	4	5	6	7	8	3	4	5	6	7	8	3	4	5	6	7	8
Default				Default				125				210				370					
0				50				130				220				380					
10				55				135				230				390					
20				60				140				240				400					
30				65				145				250				410					
40				70				150				260				420					
50				75				155				270				430					
75				80				160				280				440					
100				85				165				290				450					
125				90				170				300				460					
150				95				175				310				470					
175				100				180				320				480					
200				105				185				330				490					
225				110				190				340				500					
250				115				195				350				500					
300				120				200				360				500					

TAB.4e – Potentiometer input scale settings

Zero				Full Scale																	
SW3				SW2				SW2				SW2									
1	2	3	4	3	4	5	6	7	8	3	4	5	6	7	8	3	4	5	6	7	8
Default				Default				34				66				98					
0				5				36				68				100					
15				6				38				70				100					
20				8				40				72				100					
25				10				42				74				100					
30				12				44				76				100					
35				14				46				78				100					
40				16				48				80				100					
45				18				50				82				100					
50				20				52				84				100					
55				22				54				86				100					
60				24				56				88				100					
65				26				58				90				100					
70				28				60				92				100					
75				30				62				94				100					
80				32				64				96				100					

INSTALLATION INSTRUCTIONS

The device is suitable for fitting to DIN rails in the vertical position. For optimum operation and long life follow these instructions:

When the devices are installed side by side it may be necessary to separate them by at least 5 mm in the following cases:

- If panel temperature exceeds 45°C.
- Use of high power supply value (> 27 Vdc).
- Use of one or both current outputs.
- Use of active current input.

Make sure that sufficient air flow is provided for the device avoiding to place raceways or other objects which could obstruct the ventilation slits. Moreover it is suggested to avoid that devices are mounted above appliances generating heat; their ideal place should be in the lower part of the panel.

Install the device in a place without vibrations.

Moreover it is suggested to avoid routing conductors near power signal cables (motors, induction ovens, inverters etc...) and to use shielded cable for connecting signals.

ISOLATION STRUCTURE

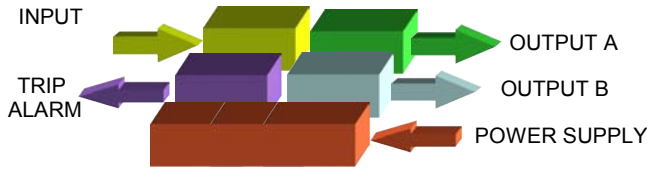

DIMENSIONS (mm)

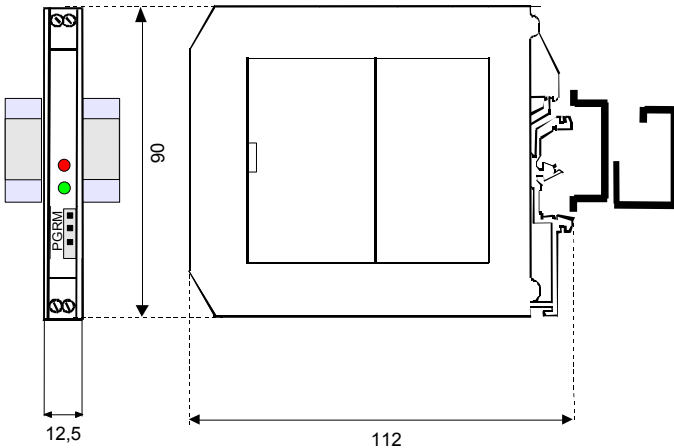

CONNECTIONS

INPUT SIDE

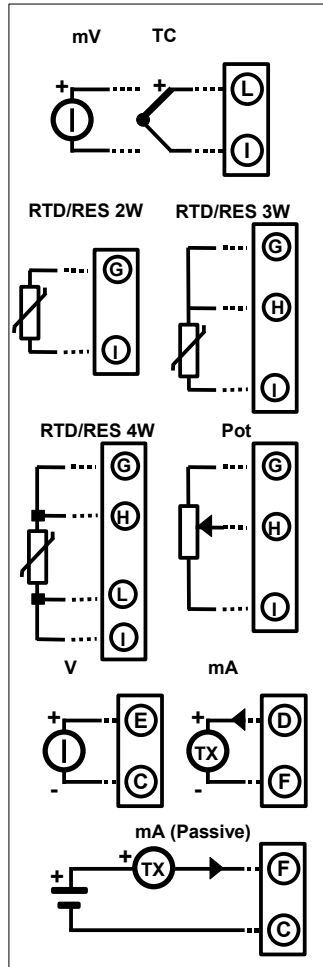

OUTPUTS SIDE

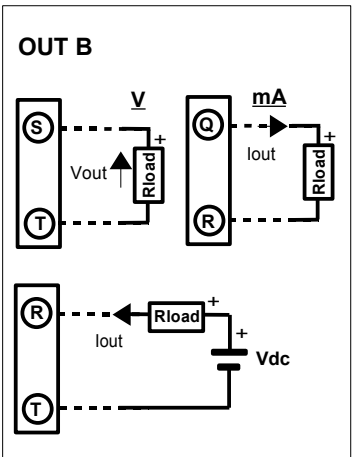
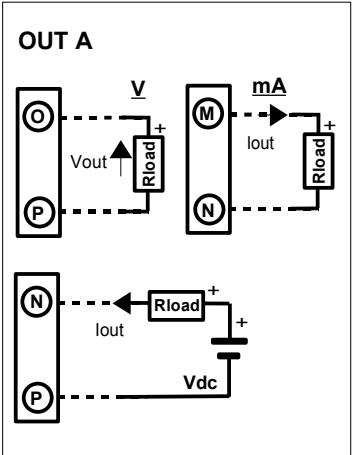

TRIP ALARM CONTACT

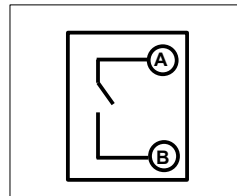

POWER SUPPLY

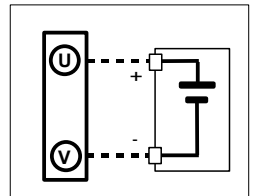

LIGHT SIGNALLING

LED	COLOUR	STATE	DESCRIPTION
PWR	GREEN	ON	Device powered
		OFF	Device not powered
		BLINKING	Wrong dip-switches settings
ALARM	RED	ON	Trip alarm active
		OFF	Trip alarm not active

HOW TO ORDER

The device is provided as requested on the Customer's order. Refer to the section "Programming" to determine the input and output ranges. In case of the configuration is not specified, the parameters must be set by the user.

ORDER CODE EXAMPLE:

DAT 4530 / Pt100 / 0 ÷ 200 °C / 4 ÷ 20 mA / 4 ÷ 20 mA / 3wires

