

## Low profile fixed range linearised transmitter for Pt100

# DAT 1111F



### FEATURES

- Input from Pt100
- Input scale in °C or °F
- Zero and Span adjustable by potentiometers
- 4÷20 mA current loop linearised output
- Good accuracy and linearity
- EMC compliant – CE mark
- Suitable for DIN B in-head mounting
- Option for DIN rail mounting in compliance with EN 50022 (DIN RAIL Option)

### GENERAL DESCRIPTION

The transmitter DAT 1111F is designed to provide on output a 4÷20 mA current loop linearised signal proportional with the temperature characteristic provided from the Pt100 connected to its input.

It is possible to connect on input both Pt100 3 wires and Pt100 2 wires sensors.

The regulation of the zero and full-scale value are made using the ZERO and SPAN potentiometers.

The DAT 1111F is in compliance with the standard 89/336/EEC on the Electromagnetic Compatibility.

It is housed in a self-extinguish plastic enclosure suitable for DIN B in-head mounting.

Moreover ( by proper mounting kit ) it is possible to mount the DAT 1111F on DIN rail.

### USER INSTRUCTIONS

The transmitter DAT 1111F must be powered by a direct voltage between 10 to 32 V applied to the terminals +V and -V.

The 4÷20 mA output signal is measurable in the power loop as shown in the section "Output/Power supply connections"; Rload is the input impedance of instruments on the current loop; to obtain a correct measure, the value of Rload will be calculated as function of the power supply value ( see section " Load characteristic").

The input connections must be made as shown in the section "Input connections".

The Pt100 three wires must be connected to the terminals 1 and 3, connecting the third wire to the terminal 2.

The Pt100 two wires must be connected to the terminals 1 and 3, connecting the terminal 2 and 3.

The calibration of the device must be made by the ZERO (calibration of the zero value) and SPAN (calibration of the full-scale value) regulations. Such operation can be made on field using a reference thermometer or using a simulator of RTD setted as the input range.

To install the transmitter refer to section "Installation Instructions".

### TECHNICAL SPECIFICATIONS (Typical at 25 °C and in nominal conditions)

<b>Input</b>	
Sensor type	RTD Pt100 in according to IEC 60751
Minimum input Span	50 °C (122 °F)
Zero values	From -50 °C (-58 °F) up to + 50 °C (122 °F)
Span values	From 50 °C (122 °F) up to 650 °C (1202 °F)
Excitation current	1 mA typ.
Line resistance influence	0.05 % of f.s./ohm (100 ohm max. balanced per wire)
<b>Output</b>	
Output type	4 ÷ 20 mA on current loop
Sensor interruption signalling	Positive out of scale (> 20 mA)
Maximum output signal	35 mA
Load resistance (Rload)	see section "Load characteristic"
Response time (from 10 to 90 % of f.s.)	300 ms
Warm-up time	3 min.
<b>Performances</b>	
Calibration error	± 0.1 % of f.s.
Linearity error (*)	± 0.15 % of f.s.
Thermal drift	0.03 % of f.s./°C
Power supply voltage (**)	10÷32 Vdc
Electromagnetic Compatibility (EMC) ( for industrial environments )	Immunity: EN 61000-6-2; Emission : EN 61000-6-4.
Operating Temperature	-20 ÷ 70 °C
Storage Temperature	-40 ÷ 85 °C
Humidity (not condensed)	0 ÷ 90%
Weight	about 35 g.

(\*)inclusive of hysteresis, linearisation error and power supply voltage variation

(\*\*)internally protected against reverse polarity.

## INSTALLATION INSTRUCTIONS

The device DAT 1111F is suitable for direct DIN B in-head mounting. The transmitter must be fixed inside the probe by the proper kit.

By apposite stirrup, provided on request, it is possible to mount the device on DIN rail in compliance with EN-50022. It is necessary to install the device in a place without vibrations; avoid to routing conductors near power signal cables .

## DAT1111F: CONNECTIONS

### INPUT CONNECTIONS

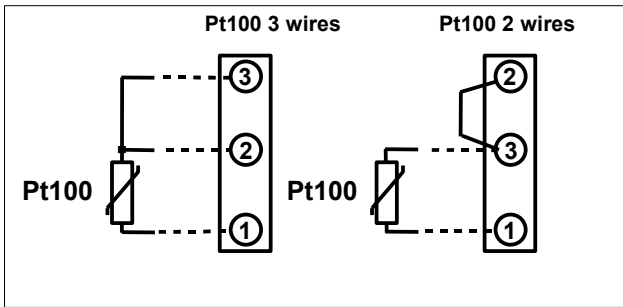

### POWER SUPPLY/OUTPUT CONNECTIONS

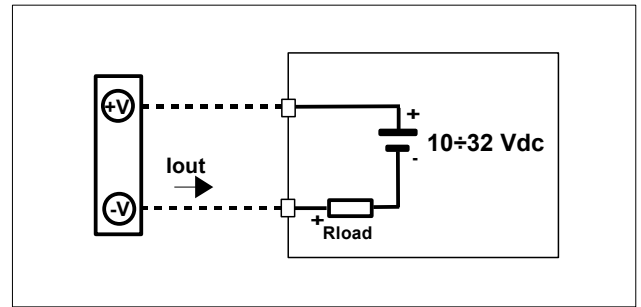

## DIMENSIONS (mm) & REGULATIONS

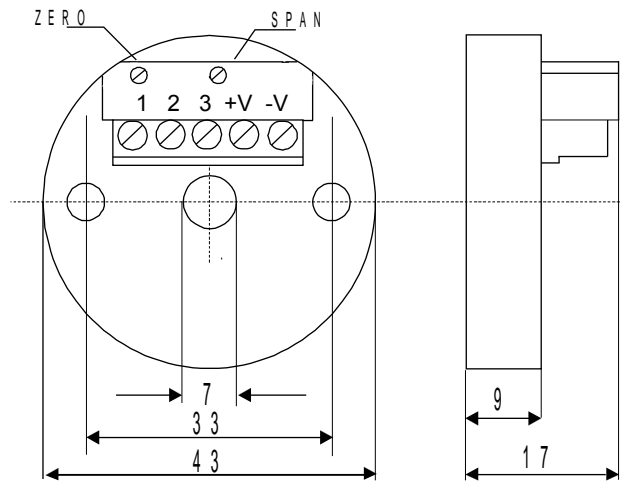

### DIN rail mounting (DIN RAIL Option)

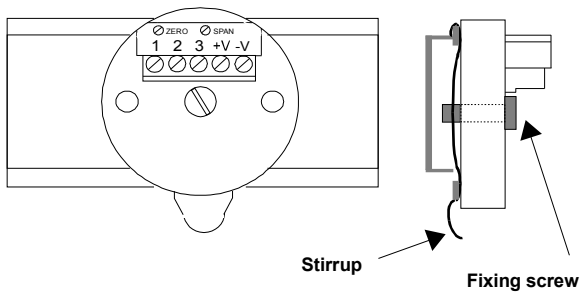

### DIN B In-head mounting

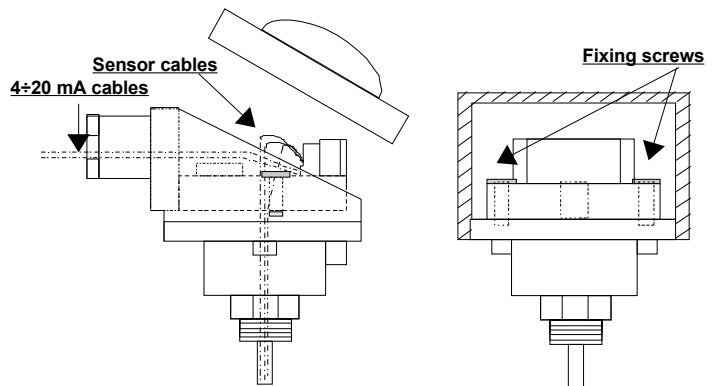

### LOAD CHARACTERISTIC

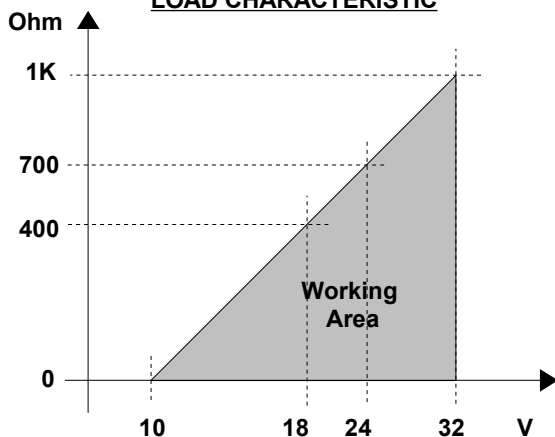

### HOW TO ORDER

The DAT1111F is provided as requested on the Customer's order. The mounting kit for DIN rail is provided **only on request** with code DIN RAIL.

### ORDER CODE EXAMPLE

DAT1111F 0÷200 °C/°F – DIN RAIL Option

Input range

Unit of measure

DIN rail mounting KIT