

Converter for potentiometer

DAT 205 3W

FEATURES

- Input for potentiometer
- Zero and Span values adjustable by potentiometers
- Linearised output in voltage or current
- Command SEL for enable / disable output
- High accuracy
- EMC compliant – CE mark
- Suitable for DIN rail mounting in compliance with EN 50022 and EN-50035



GENERAL DESCRIPTION

The converter DAT 205 3W is designed to provide on output a linearised voltage or current signal proportional with the variation of resistance introduced from the potentiometer connected to its input; to make the measure, a 1 Vdc voltage reference is provided at the ends of the potentiometer .

The regulations of the zero and full-scale value are made using the ZERO and SPAN potentiometers; there is not influence between the regulations.

The command SEL must be used to enable or disable the output of the device in the case in which will be necessary to connect more than one DAT 205 3W to only one A/D input.

The DAT 205 3W is in compliance with the standard 89/336/EEC on the Electromagnetic Compatibility.

It is housed in a plastic enclosure of 17 mm thickness suitable for DIN rail mounting in compliance with EN-50022 and EN-50035 standards.

USER INSTRUCTIONS

The converter DAT 205 3W must be powered by a direct voltage between 18 to 30 V applied to the terminals G (+V) and H (GND).

The output connections must be made as shown in the section "Output connections".

The output signal is measurable between the terminals F (OUT V/I) and H (GND).

The command SEL operates connecting a voltage signal from 5 up to 30 Vdc between the terminals E (SEL) and H (GND);if the terminal E (SEL) is not connected or it is connected to the terminal H (GND), the device remains in the measure condition .

The input connections must be made as shown in the section "Input connections".

The ends of the potentiometer must be connected to the terminals B and A, while the central terminal must be connected to the terminal C.

The calibration of the device must be made by the ZERO (calibration of the zero value) and SPAN (calibration of the full-scale value) regulations. Such operation can be made on field referring to the section "DAT 205 3W: CALIBRATION".

To install the converter refer to section "Installation Instructions".

TECHNICAL SPECIFICATIONS (Typical at 25 °C and in nominal conditions)	
Input	
Sensor type	Potentiometer
Potentiometer's resistance	Minimum nominal value = 1 K Ω ; Maximum nominal value = 10 K Ω .
Voltage reference	1Vdc
Output	
Output type	4 \div 20 mA, 0 \div 20 mA or 0 \div 10 V
Maximum output signal	15 V or 25 mA
Load resistance (Rload)	Current output: \leq 500 Ω Voltage output: \geq 2 K Ω
Response time (from 10 to 90 % of f.s.)	500 ms
Warm-up time	3 min.
SEL command	
Disable output	5 \div 30 Vdc
Enable output	0 Vdc or not connected
Performances	
Calibration error	\pm 0.1 % of f.s.
Linearity error (*)	\pm 0.1 % of f.s.
Thermal drift	0.02 % of f.s./ $^{\circ}$ C
Power supply voltage (**)	18 \div 30 Vdc
Current consumption	Current output: 30 mA max. Voltage output: 10 mA max.
Electromagnetic Compatibility (EMC) (for industrial environments)	Immunity: EN 61000-6-2; Emission : EN 61000-6-4.
Operating Temperature	-20 \div 70 $^{\circ}$ C
Storage Temperature	-40 \div 85 $^{\circ}$ C
Humidity (not condensed)	0 \div 90%
Weight	about 50 g.
(*)inclusive of hysteresis, linearisation error and power supply voltage variation	
(**)internally protected against reverse polarity.	

INSTALLATION INSTRUCTIONS

The device DAT 205 3W is suitable for DIN rail mounting.

It is necessary to install the device in a place without vibrations; avoid to routing conductors near power signal cables .

DAT 205 3W: CALIBRATION

With the ends of the potentiometer connected:

Calibration of the minimum scale value :

Connect the terminal C to the terminal A and regulate the minimum output value by the ZERO potentiometer.

Calibration of the maximum scale value

Connect the terminal C to the terminal B and regulate the maximum output value by the SPAN potentiometer.

DAT205 3W CONNECTIONS

INPUT CONNECTIONS

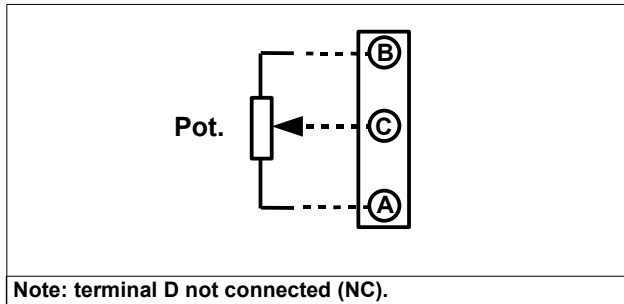

POWER SUPPLY/OUTPUT CONNECTIONS

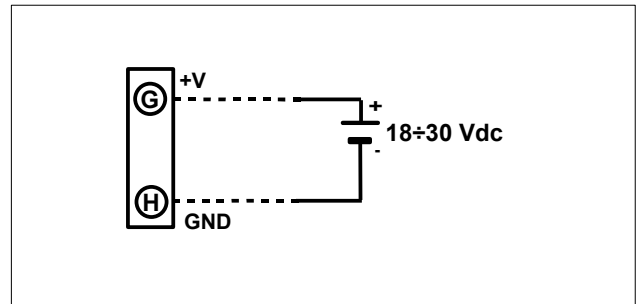

OUTPUT CONNECTIONS

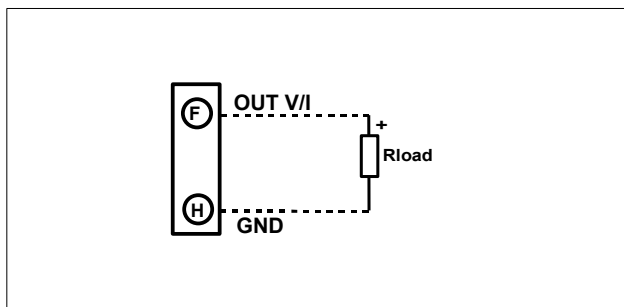

SEL CONNECTIONS

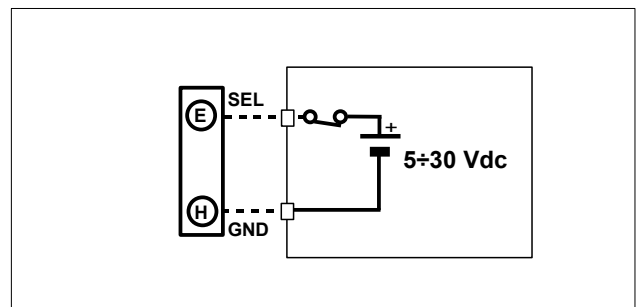

DIMENSIONS (mm) & REGULATIONS

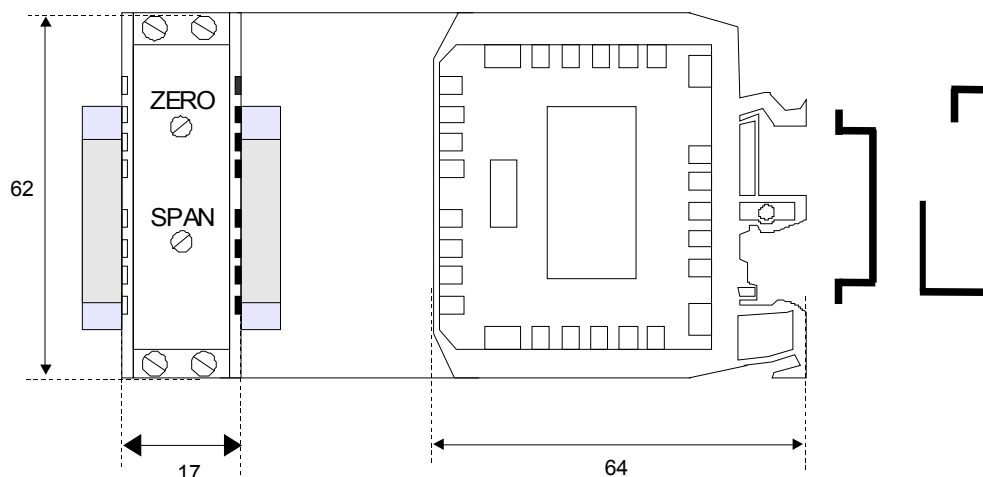

HOW TO ORDER

The DAT 205 3W is supplied to connect potentiometers with nominal value included between 1 and 10 K Ω .

ORDER CODE: DAT205 3W **0÷10 V**

Output value